

NORTHROCK

NORTHROCKBIKES.COM

Welcome, and congratulations on the purchase of your new Northrock Bicycle. □
Before you take your bicycle for a ride we encourage you to complete the following information for future reference, and we suggest you read through the owner's manual to familiarize yourself with the operations of your new high quality Northrock Bicycle. The best ride is a safe ride.



Shimano owner's manual for e bicycles. Also accessible on northrockbikes.com/support/downloads.



For additional support consult a Shimano Service Center: <https://www.shimanoservicecenter.com/us/about> or scan the following:



- Before riding we recommend consulting a bicycle specialist for proper assembly and maintenance.
- We recommend consulting your local laws and regulations for e-bikes.
- We do not recommend towing or including children's seats.
- Before your first ride we suggest you read the enclosed owner's manual and seek an open safe space to become familiar with the features and brakes.
- Have fun, wear a bicycle helmet, be safe, and follow the rules.

Northrock Customer Service you can reach us:

Visit www.northrockbikes.com or scan here for Support:



Telephone: 888-269-5525 9:00AM-5:00PM Eastern Standard Time Monday through Friday. Our team is here to help.

Be kind to the planet, reduce waste. Please contact our Support before returning.

To ***support assembly***, included in the parts box are assembly instructions for your bicycle. For instructional videos, visit Northrock *Shop Talk* at www.northrockbikes.com or scan here.



FAQ - Questions? Find the answer to most questions. Scan here:



Note: Shop Talk videos and FAQ are intended as a guide only and do not take the place of the official Northrock Owner's Manual and or component providers instructions.

Before riding it is recommended that a bicycle specialist be consulted for final assembly and safety check to assure the bicycle is properly assembled.

Thank you for purchasing a Northrock Bicycle. We love building the bicycles you love riding. Have fun, be safe and welcome to Northrock Nation of Riders.

WARRANTY AND PURCHASE INFORMATION

Please fill out the following information and keep for your own records. Please retain your sales receipt in the event of any possible warranty claims.

Model Name: _____

Bicycle Color: _____

Serial #: _____

(See diagram below for location)

Date of Purchase: _____

Place of Purchase: _____

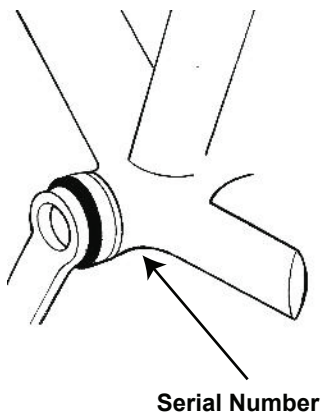

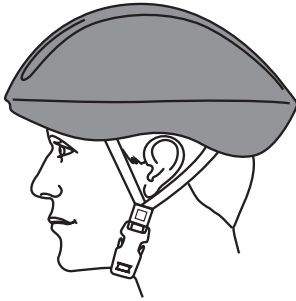

CORRECT FITTING - MAKE SURE YOUR HELMET COVERS YOUR FOREHEAD.

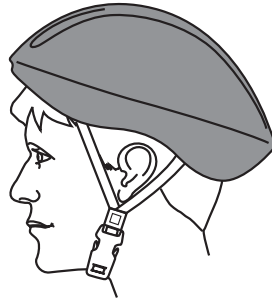

INCORRECT FITTING. FOREHEAD IS EXPOSED AND VULNERABLE TO SERIOUS INJURY.

HELMETS SAVE LIVES !!!

**ALWAYS WEAR A PROPERLY
FITTED HELMET WHEN
YOU RIDE YOUR BICYCLE.
DO NOT RIDE AT NIGHT.
AVOID RIDING IN WET
CONDITIONS.**

CONTENTS

General Warning	P. 6
A Special Note To Parents	P. 7

1. First

A. Bike Fit	P. 8
B. Safety First	P. 8
C. Mechanical Safety Check	P. 9
D. First Ride	P. 10

2. Safety

A. The Basics	P. 11
B. Riding Safety	P. 12
C. Off Road Safety	P. 13
D. Wet Weather Riding	P. 14
E. Night Riding	P. 14
F. Extreme, Stunt or Competition Riding	P. 15
G. Changing Components or Adding Accessories	P. 16

3. Assembly Guide

P. 17

4. Technical Information

A. Wheels	P. 18
1. Wheel Quick Release	P. 18
2. Removing and Installing Quick Release Wheels	P. 19
3. Removing and Installing Bolt-On Wheels	P. 22
B. Seatpost Quick Release	P. 23
C. Brakes	P. 24
D. Shifting Gears	P. 26
E. Derailleur Adjustment - How To	P. 28
F. Pedals	P. 30
G. Bicycle Suspension	P. 32
H. Tires and Tubes	P. 33

5. Fit

A. Standover Height	P. 35
B. Saddle Position	P. 35
C. Handlebar Height and Angle	P. 37
D. Control Position Adjustments	P. 38
E. Brake Reach	P. 38
F. Stem and Handlebar Adjustment	P. 38

6. Service

A. Service Intervals	P. 39
B. If your bicycle sustains an impact	P. 41

7. Appendix

P. 42

8. Warranty



P. 43

NOTE: This manual is not intended as a comprehensive use, service, repair, assembly or maintenance manual. Please consult a qualified bicycle specialist and the specified manufacture instructions for service and/or assembly questions.

GENERAL WARNING:

Like any sport, bicycling involves risk of injury and damage. By choosing to ride a bicycle, you assume the responsibility for that risk, so you need to know - and to practice - the rules of safe and responsible riding and of proper use and maintenance. Proper use and maintenance of your bicycle reduces risk of injury.

This Manual contains many “Warnings” and “Cautions” concerning the consequences of failure to maintain or inspect your bicycle and of failure to follow safe cycling practices.

- The combination of the  safety alert symbol and the word **WARNING** indicates a potentially hazardous situation which, if not avoided, could result in serious injury or death.
- The combination of the  safety alert symbol and the word **CAUTION** indicates a potentially hazardous situation which, if not avoided, may result in minor or moderate injury, or is an alert against unsafe practices.
- The word **CAUTION** used without the safety alert symbol indicates a situation which, if not avoided, could result in serious damage to the bicycle or the voiding of your warranty.

Many of the Warnings and Cautions say “you may lose control and fall”. Because any fall can result in serious injury or even death, we do not always repeat the warning of possible injury or death.

Because it is impossible to anticipate every situation or condition which can occur while riding, this Manual makes no representation about the safe use of the bicycle under all conditions. There are risks associated with the use of any bicycle which cannot be predicted or avoided, and which are the sole responsibility of the rider.

A special note for parents:

As a parent or guardian, you are responsible for the activities and safety of your minor child, and that includes making sure that the bicycle is properly fitted to the child; that it is in good repair and safe operating condition; that you and your child have learned and understand the safe operation of the bicycle; and that you and your child have learned, understand and obey not only the applicable local motor vehicle, safe and responsible bicycling. As a parent, you should read this manual, as well as review its warnings and the bicycle's functions and operating procedures with your child, before letting your child ride the bicycle.

 **WARNING:** Make sure that your child always wears an approved bicycle helmet when riding; but also make sure that your child understands that a bicycle helmet is for bicycling only, and must be removed when not riding. A helmet must not be worn while playing, in play areas, on playground equipment, while climbing trees, or at any time while not riding a bicycle. Failure to follow this warning could result in serious injury or death. All wheels over 26 in intended for adult use.

1. First

NOTE: We strongly urge you to read this Manual in its entirety before your first ride, but at the very least, read and make sure that you understand each point in this section, and refer to the cited sections on any issue which you don't completely understand.

A. Bike fit

1. Is your bike the right size? To check, see Section 5.A. If your bicycle is too large or too small for you, you may lose control and fall.
2. Is the saddle at the right height? To check, see Section 5.B. If you adjust your saddle height, make sure that you follow the Minimum Insertion instructions in Section 5.B.
3. Are the saddle and seatpost securely clamped? To check, see Section 5.B. A properly tightened saddle will allow no saddle movement in any direction.
4. Are the stem and handlebars at the proper height for you? To check, see Section 5.C on what you can do about it.
5. Can you comfortably operate the brakes? To check, see Section 5.D and 5.E. If not, you may be able to adjust their angle and reach.
6. Do you fully understand how to operate your new bicycle? If not, before your first ride, have a bicycle specialist explain any functions or features which you do not understand.

B. Safety first

1. Always wear an approved helmet when riding your bike, and follow the helmet manufacturer's instructions for fit, use and care of your helmet.
2. Do you have all the other required and recommended safety equipment? See Section 2. It's your responsibility to familiarize yourself with the laws of the areas where you ride, and to comply with all applicable laws.
3. Do you know how to correctly operate your wheel quick releases? See Section 4.A.1 to make sure. Riding with an improperly adjusted wheel quick release can cause the wheel to wobble or disengage from the bicycle, and cause serious injury or death.
4. If your bike has toeclips and straps or clipless ("step-in") pedals, make sure you know how they work (see Section 4.F). These pedals require special techniques and skills. Follow the pedal manufacturer's instructions for use, adjustment and care.

5. Does your bike have suspension? If so, check Section 4.G. Suspension can change the way a bicycle performs. Follow the suspension manufacturer's instructions for use, adjustment and care.

6. Do you have "toe overlap"? On smaller framed bicycles your toe or toeclip may be able to contact the front wheel when a pedal is all the way forward and the wheel is turned. See section 4.F.

C. Mechanical safety check

Routinely check the condition of your bicycle ride.

Nuts, Bolts and Straps: Make sure nothing is loose. Lift the front wheel off the ground by 5 to 7.6 cm (2 to 3 in), then let it bounce on the ground. Anything sound, feel or look loose? Do a quick visual and tactile inspection of the whole bike. Any loose parts or accessories? If so, secure them. If you're not sure, ask someone with experience to check.

Tires and Wheels: Make sure tires are correctly inflated (see Section 4.H.1). Check by putting one hand on the saddle, one on the intersection of the handlebars and stem, then bouncing your weight on the bike while looking at tire deflection. Compare what you see with how it looks when you are correctly inflated, and adjust if necessary.

Are the tires in good shape? Spin each wheel slowly and look for cuts in the tread and sidewall. Replace damaged tires before riding the bike.

Are the wheels true? Spin each wheel and check for brake clearance and side-to-side wobble. If a wheel wobbles side to side even slightly, or rubs against or hits the brake pads, take the bike to a qualified bike shop to have the wheel trued.

 **CAUTION: Wheels must be true for the brakes to work effectively. Wheel truing is a skill which requires special tools and experience. Do not attempt to true a wheel unless you have the knowledge, experience and tools needed to do the job correctly.**

Brakes: Check the brakes for proper operation (see Sections 4.C). Squeeze the brake levers. Are the brake quick releases closed? All control cables seated and securely engaged? Do the brake pads touch the wheel rim within an inch of brake lever movement? Can you apply full braking force at the levers without having them touch the handlebar? If not, your brakes need adjustment. Do not ride the bike until the brakes are properly adjusted.

Bearings: Make sure bearings are lubricated, run freely, and serviced. Seek a qualified bicycle specialist for proper maintenance and servicing.

Quick Releases: Make sure the front wheel, rear wheel and seat post quick releases are properly adjusted and in the locked position. See Section 4.A and 4.B.

Handlebar and Saddle Alignment: Make sure the saddle and handlebar stem are parallel to the bike's center line and clamped tight so it won't twist out of alignment. See Sections 5.B and 5.C. If not, align and tighten them.

Handlebar ends: Make sure the handlebar grips are secure and in good condition. If not, replace them. Make sure the handlebar ends and extensions are plugged. If not, plug them before you ride. If the handlebars have bar end extensions, make sure they are clamped tight so they won't twist. If not, tighten them.

 **WARNING: Loose or damaged handlebar grips or extensions can cause you to lose control and fall. Unplugged handlebars or extensions can cut your body, and can cause serious injury in an otherwise minor accident.**

D. First ride

When you buckle on your helmet and go for your first familiarization ride on your new bicycle, be sure to pick a controlled environment, away from cars, other cyclists, obstacles or other hazards. Ride to become familiar with the controls, features and performance of your new bike.

Familiarize yourself with the **braking action** of the bike (see Section 4.C). Test the brakes at slow speed, putting your weight toward the rear and gently applying the brakes rear brake first. Sudden or excessive application of the front brake could pitch you over the handlebars. Applying brakes too hard can lock up a wheel, which could cause you to lose control and fall.

If your bicycle has **toeclips** or **clipless pedals**, practice getting in and out of the pedals. See paragraph B.4 above.

If your bike has **suspension**, familiarize yourself with how the suspension responds to brake application and rider weight shifts. See paragraph B.5 above and Section 4.G.

Practice **shifting the gears** (see Section 4.D). Remember to never move the shifter while pedaling backward, nor pedal backwards after immediately having moved the shifter. This could jam the chain and cause serious damage to the bicycle.

Check out the handling and response of the bike, and check the comfort.

2. Safety

A. The basics

⚠ WARNING: Many states require specific safety devices. It is your responsibility to familiarize yourself with the laws of the state where you ride and to comply with all applicable laws, including properly equipping yourself and your bike as the law requires. b

Observe all local bicycle laws and regulations. Observe regulations about licensing of bicycles, riding on sidewalks, laws regulating bike path and trail use, helmet laws, child carrier laws, special bicycle traffic laws, and so on. It's your responsibility to know and obey the laws.



1. Always wear a cycling helmet which meets the latest certification standards and follow the helmet manufacturer's instructions for fit, use and care of your helmet. Most serious bicycle injuries involve head injuries which might have been avoided if the rider had worn a helmet.

⚠ WARNING: Failure to wear a helmet while riding may result in serious injury or death.

2. Always do the Mechanical Safety Check (Section 1.C) before you get on a bike.

3. Be thoroughly familiar with the controls of your bicycle: brakes, pedals, shifters.

4. Be careful to keep body parts and other objects away from the sharp teeth of chainrings; the moving chain; the turning pedals and cranks; and the spinning wheels of your bicycle.

5. Always wear:

- Shoes that will stay on your feet and will grip the pedals. Never ride barefoot or while wearing sandals.
- Bright, visible clothing that is not so loose that it can be tangled in the bicycle or snagged by objects at the side of the road or trail.
- Protective eyewear, to protect against airborne dirt, dust and bugs - tinted when the sun is bright, clear when it's not.

⚠ WARNING: Jumping your bike may result in serious injury or death

6. Don't jump with your bike. Jumping a bike, particularly a BMX or mountain bike, can be fun, but it puts incredible stress on everything from your spokes to your pedals. Riders who insist on jumping their bikes risk serious damage, to their bicycles as well as to themselves.

7. Ride at a speed appropriate for conditions. Increased speed means higher risk.

B. Riding safety

1. You are sharing the road or the path with others — motorists, pedestrians and other cyclists. Respect their rights.
2. Ride defensively. Always assume that others do not see you.
3. Look ahead, and be ready to avoid:
 - Vehicles slowing or turning, entering the road or your lane ahead of you, or coming up behind you.
 - Parked car doors opening.
 - Pedestrians stepping out.
 - Children or pets playing near the road.
 - Pot holes, sewer grating, railroad tracks, expansion joints, road or sidewalk construction, debris and other obstructions that could cause you to swerve into traffic, catch your wheel or otherwise cause you to lose control and have an accident.
 - The many other hazards and distractions which can occur on a bicycle ride.
4. Ride in designated bike lanes, on designated bike paths or as close to the edge of the road as possible, in the direction of traffic flow, or as directed by local governing laws.
5. Stop at stop signs and traffic lights; slow down and look both ways at street intersections. Remember that a bicycle always loses in a collision with a motor vehicle, so be prepared to yield even if you have the right of way.
6. Use approved hand signals for turning and stopping.
7. Never ride with headphones or cell phone. They mask traffic sounds and emergency vehicle sirens, distract you from concentrating on what's going on around you, and their wires can tangle in the moving parts of the bicycle, causing you to lose control.
8. Never carry a passenger, unless it is a small child wearing an approved helmet and secured in a correctly mounted child carrier or a child-carrying trailer.
9. Never carry anything which obstructs your vision or your complete control of the bicycle, or which could become entangled in the moving parts of the bicycle.
10. Never hitch a ride by holding on to another vehicle.
11. Don't do stunts, wheelies or jumps. If you intend to do stunts, wheelies, jumps or go racing with your bike despite our advice not to read Section 2.F, Downhill, Stunt or Competition Biking, now. Think carefully about your skills before deciding to take the large risks that go with this kind of riding.
12. Don't weave through traffic or make any moves that may surprise people with whom you are sharing the road.
13. Observe and yield the right of way.

14. Never ride your bicycle while under the influence of alcohol or drugs.

15. If possible, avoid riding in bad weather, when visibility is obscured, at dawn, dusk or in the dark, or when extremely tired. Each of these conditions increases the risk of accident.

C Off-road safety

We recommend that children do not ride on rough terrain unless they are accompanied by an adult.

1. The variable conditions and hazards of off-road riding require close attention and specific skills. Start slowly on easier terrain and build up your skills. If your bike has suspension, the increased speed you may develop also increases your risk of losing control and falling. Get to know how to handle your bike safely before trying increased speed or more difficult terrain.

2. Wear safety gear appropriate to the kind of riding you plan to do.

3. Don't ride alone in remote areas. Even when riding with others, make sure that someone knows where you're going and when you expect to be back.

4. Be prepared always take along some kind of identification, so that people know who you are in case of an accident; and take along a couple of dollars in cash and carry a cell phone for emergency use only.

5. Yield right of way to pedestrians and animals. Ride in a way that does not frighten or endanger them, and stay far enough away so that their unexpected moves don't endanger you.

6. Be prepared. If something goes wrong while you're riding off-road, help may not be close.

7. If you intend to jump, do stunt riding or race with your bike despite our advice not to, read and understand Section 2.F.

Off-Road Respect

Obey the local laws regulating where and how you can ride off-road, and respect private property. You may be sharing the trail with others — hikers, equestrians, other cyclists. Respect their right.

D. Wet weather riding

⚠ WARNING: Wet weather impairs traction, braking and visibility, both for the bicyclist and for other vehicles sharing the road. The risk of an accident is dramatically increased in wet conditions.

Under wet conditions, the stopping power of your brakes (as well as the brakes of other vehicles sharing the road) is dramatically reduced and your tires don't grip nearly as well. This makes it harder to control speed and easier to lose control. To make sure that you can slow down and stop safely in wet conditions, ride more slowly and apply your brakes earlier and more gradually than you would under normal, dry conditions.

E. Night riding

Riding a bicycle at night is many times more dangerous than riding during the day. A bicyclist is very difficult for motorists and pedestrians to see. Therefore, children should never ride at dawn, at dusk or at night. Adults who choose to accept the greatly increased risk of riding at dawn, at dusk or at night need to take extra care both riding and choosing specialized equipment which helps reduce that risk. Consult a qualified specialist about night riding safety equipment.

⚠ WARNING: Reflectors are not a substitute for required lights. Riding at dawn, at dusk, at night or at other times of poor visibility without an adequate bicycle lighting system and without reflectors is dangerous and may result in serious injury or death.

Bicycle reflectors are designed to pick up and reflect street lights and car lights in a way that may help you to be seen and recognized as a moving bicyclist.

⚠ CAUTION: Check reflectors and their mounting brackets regularly to make sure that they are clean, straight, unbroken and securely mounted. Have a bicycle specialist replace damaged reflectors and straighten or tighten any that are bent or loose.

The mounting brackets of front and rear reflectors are often designed as brake straddle cable safety catches which prevent the straddle cable from catching on the tire tread if the cable jumps out of its yoke or breaks.

⚠ WARNING: Do not remove the front or rear reflectors or reflector brackets from your bicycle. They are an integral part of the bicycle's safety system.

Removing the reflectors may reduce your visibility to others using the roadway. Being struck by other vehicles may result in serious injury or death.

The reflector brackets may protect you from the brake straddle cable catching on the tire in the event of brake cable failure. If a brake straddle cable catches on the tire, it can cause the wheel to stop suddenly, causing you to lose control and fall.

If you choose to ride under conditions of poor visibility, check and be sure you comply with all local laws about night riding, and take the following strongly recommended additional precautions:

- Purchase and install battery or generator-powered head and tail lights which meet all regulatory requirements and provide adequate visibility.
- Wear light colored, reflective clothing and accessories, such as a reflective vest, reflective arm and leg bands, reflective stripes on your helmet, flashing lights attached reflective device or light source that moves will help you get the attention of approaching motorists, pedestrians and other traffic.
- Make sure your clothing or anything you may be carrying on the bicycle does not obstruct a reflector or light.
- Make sure that your bicycle is equipped with correctly positioned and securely mounted reflectors.

 **WARNING: Rear reflector on seatpost: Rear reflector must be positioned so that it clears the rear tire and must be visible above the rear tire.**

While riding at dawn, at dusk or at night:

- Ride slowly.
- Avoid dark areas and areas of heavy or fast-moving traffic.
- Avoid road hazards.
- If possible, ride on familiar routes.

If riding in traffic:

- Be predictable. Ride so that drivers can see you and predict your movements.
- Be alert. Ride defensively and expect the unexpected.
- If you plan to ride in traffic often, ask a bicycle specialist about traffic safety classes or a good book on bicycle traffic safety.

F. Extreme, stunt or competition riding

 **WARNING: Jumping your bike may result in serious injury or death**

Whether you call it Aggro, Hucking, Freeride, North Shore, Downhill, Jumping, Stunt Riding, Racing or something else: by engaging in this sort of extreme, aggressive riding you voluntarily assume an increased risk of injury or death.

Not all bicycles are designed for these types of riding, and those that are may not be suitable for all types of aggressive riding. Check with a bicycle specialist or the bicycle's manufacturer about the suitability of your bicycle before engaging in extreme riding.

When riding fast downhill, you can reach speeds seen on motorcycles, and therefore face similar hazards and risks. Have your bicycle and equipment carefully inspected by a qualified bicycle mechanic and be sure it is in perfect condition. Consult with expert riders and race officials on conditions and equipment advisable at the site where you plan to ride. Wear appropriate safety gear, including an approved full face helmet, full finger gloves, and body armor.

Ultimately, it is your responsibility to have proper equipment and to be familiar with course conditions

⚠ WARNING: Although many catalogs, advertisements and articles about bicycling depict rider engaged in extreme riding, this activity is extremely dangerous, increases your risk of injury or death, and increases the severity of any injury. Remember that the action depicted is being performed by professionals with many years of training and experience. Know your limits and always wear a helmet and other appropriate safety gear. Even with state-of-the-art protective safety gear, you could be seriously injured or killed when jumping, stunt riding, riding downhill at speed or in competition.

⚠ CAUTION: Bicycles and bicycle parts have limitations with regard to strength and integrity, and this type of riding can exceed those limitations.

We recommend against this type of riding because of the increased risks, but if you choose to take the risk, at least:

- Take lessons from a competent instructor first.
- Start with easy learning exercises and slowly develop your skills before trying more difficult or dangerous riding.
- Do stunts, jumping, racing or fast downhill riding only in areas designated for this type of riding.
- Wear a full face helmet, safety pads and other safety gear.
- Understand and recognize that the stresses imposed on your bike by this kind of activity may break or damage parts of the bicycle and void the warranty.
- Take your bicycle to a bicycle specialist if anything breaks or bends. Do not ride your bicycle when any part is damaged.

If you ride downhill at speed, do stunt riding or ride in competition, know the limits of skill and experience. Ultimately, avoiding injury is your responsibility.

G. Changing components or adding accessories

There are many components and accessories available to enhance the comfort, performance and appearance of your bicycle. However, if you change components or add accessories, you do so at your own risk. The bicycle's manufacturer may not have tested that component or accessory for compatibility, reliability or safety on your bicycle. Before installing any component or accessory, including a different size tire, make sure that it is compatible with your bicycle by checking with a bicycle specialist. Be sure to read, understand and follow the instructions that accompany the products you purchase for your bicycle.

⚠ WARNING: Failure to confirm compatibility, properly install, operate and maintain any component or accessory can result in serious injury or death.

⚠ CAUTION: Changing the components on your bike may void the bicycle warranty. Refer to the warranty, and check with a bicycle specialist before changing the components on your bike.

3. Assembly Guide

FOR DETAILED ASSEMBLY INSTRUCTIONS, PLEASE REFER TO THE QUICK ASSEMBLY GUIDE LOCATED IN THE PARTS BOX.

BEFORE RIDING IT IS RECOMMENDED THAT A BICYCLE SPECIALIST BE CONSULTED FOR FINAL ASSEMBLY AND SAFETY CHECK TO ASSURE THE BICYCLE IS PROPERLY ASSEMBLED.

NORTHROCK BICYCLES ASSUMES NO RESPONSIBILITY FOR IMPROPER ASSEMBLY AND/OR FAILURE TO FOLLOW SAFE CYCLING PRACTICES.

*FOR INSTUCTIONAL VIDEOS VISIT NORTHROCK SHOP TALK AT
www.northrockbikes.com, OR SCAN HERE:*



For assistance, visit www.northrockbikes.com or scan here for Support:



Tools Required: Every bicycle model will differ for assembly or maintenance tools. It is recommended to consult a qualified bicycle specialist or the appropriate component manufacturers' instructions. General tools are: Allen keys (4mm, 5mm, 6mm and 8mm), adjustable wrench (9mm, 10mm, 14mm and 15mm), pliers with cable cutting ability, Phillips head screwdriver and bicycle pump.

Warning: If applicable, stem minimum insertion line must be hidden within the headtube of the bicycle. Over tightening the stem bolt or headset assembly may cause damage to the bicycle and/or injury to the rider.

Warning: The seat post must be inserted so that the minimum insertion mark cannot be seen. The quick release mechanism must be tightened securely to prevent a sudden shift of the seat when riding. Failure to do this may cause loss of bicycle control.

Note: Shop Talk videos are intended as a guide only and do not take the place of the official Northrock Owner's Manual and or component providers instructions.

4. Technical Information

It's important to your safety, performance and enjoyment to understand how things work on your bicycle. If you have even the slightest doubt as to whether you understand something in this section of the Manual, talk to a bicycle specialist.

A. Wheels

NOTE: If you have a mountain bike equipped with through axle front or rear wheels, make sure you have the manufacturer's instructions, and follow those when installing or removing a through axle wheel. If you don't know what a through axle is, ask a bicycle specialist or contact Northrock Bicycles.

1. Wheel Quick Release

⚠ WARNING: Riding with an improperly adjusted wheel quick release can allow the wheel to wobble or fall off the bicycle, which can cause serious injury or death. Therefore, it is essential that you:

1. Ask a bicycle specialist to help you make sure you know how to install and remove your wheels safely.
2. Understand and apply the correct technique for clamping your wheel in place with a quick release.
3. Each time, before you ride the bike, check that the wheel is securely clamped.

The wheel quick release uses a cam action to clamp the bike's wheel in place (see fig. 5). Because of its adjustable nature, it is critical that you understand how it works, how to use it properly, and how much force you need to apply to secure the wheel.

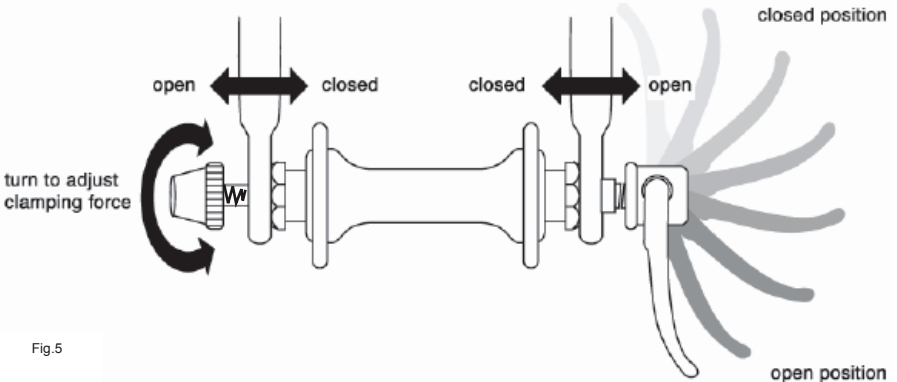

Fig.5

⚠ WARNING: The full force of the cam action is needed to clamp the wheel securely. Holding the nut with one hand and turning the lever like a wing nut with the other hand until everything is as tight as you can get.

a. Adjusting the Quick Release Mechanism

The wheel hub is clamped in place by the force of the quick release cam pushing against one dropout and pulling the tension adjusting nut, by way of the skewer, against the other dropout. The amount of clamping force is controlled by the tension adjusting nut. Turning the tension adjusting nut clockwise while keeping the cam lever from rotating increases clamping force; turning it counterclockwise while keeping the cam lever from rotating reduces clamping force. Less than half a turn of the tension adjusting nut can make the difference between safe clamping force and unsafe clamping force.

b. Front Wheel Secondary Retention Devices

Most bicycles have front forks which utilize a secondary wheel retention device to reduce the risk of the wheel disengaging from the fork if the quick release is incorrectly adjusted. Secondary retention devices are not a substitute for correct quick release adjustment.

Secondary retention devices fall into two basic categories:

- (1) The clip-on type is a part which the manufacturer adds to the front wheel hub or front fork.
- (2) The integral type is molded, cast or machined into the outer faces of the front fork dropouts.

Ask a bicycle specialist to explain the particular secondary retention device on your bike.

⚠ WARNING: Do not remove or disable the secondary retention device. As its name implies, it serves as a back-up for a critical adjustment. If the quick release is not adjusted correctly, the secondary retention device can reduce the risk of the wheel disengaging from the fork. Removing or disabling the secondary retention device may also void the warranty.

Secondary retention devices are not a substitute for correct quick release adjustment. Failure to properly adjust the quick release mechanism can cause the wheel to wobble or disengage, which could cause you to lose control and fall, resulting in serious injury or death.

2. Removing and Installing Quick Release Wheels (See Appendix A)

a. Removing a Quick Release Front Wheel

⚠ CAUTION: If your bike has a disc front brake, exercise care in touching it. Discs have sharp edges and can get very hot during use.

- (1) If your bike has rim brakes, disengage the brake's quick-release mechanism to increase the clearance between the tire and the brake pads (See Section 4.C figs. 12 through 13).
- (2) Move the wheel's quick-release lever from the locked or CLOSED position to the OPEN position (figs. 6 & 7).
- (3) If your front fork does not have a secondary retention device go to step (5).

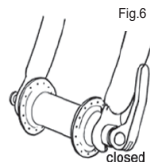

(4) If your front fork has a clip-on type secondary retention device, disengage it and go to step (5). If your front fork has an integral secondary retention device, loosen the tension adjusting nut enough to allow removing the wheel; then go to loosen the tension adjusting nut enough to allow removing the wheel; then go to the next step.

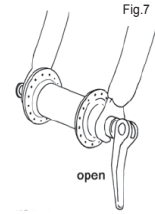

(5) Raise the front wheel a few inches off the ground and tap the top of the wheel with the palm of your hand to release the wheel from the front fork.

b. Installing a Quick Release Front Wheel

⚠ CAUTION: If your bike is equipped with disk brakes, be careful not to damage the disk, caliper or brake pads when re-inserting the disk into the caliper. Never activate a disk brake's control lever unless the disk is correctly inserted in the caliper. See also Section 4.C.

(1) Move the quick-release lever so that it curves away from the wheel (fig. 7). This is the OPEN position.

(2) With the steering fork facing forward, insert the wheel between the fork blades so that the axle seats firmly at the top of the slots which are at the tips of the fork blades --the fork dropouts. The quick-release lever should be on the left side of the bicycle (fig.6 & 7). If your bike has a clip-on type secondary retention device, engage it.

(3) Holding the quick-release lever in the OPEN position with your right hand, tighten the tension adjusting nut with your left hand until it is finger tight against the fork dropout (fig. 5).

(4) While pushing the wheel firmly to the top of the slots in the fork dropouts, and at the same time centering the wheel rim in the fork, move the quick-release lever upwards and swing it into the CLOSED position (fig. 5 & 6). The lever should now be parallel to the fork blade and curved toward the wheel. To apply enough clamping force, you should have to wrap your fingers around the fork blade for leverage, and the lever should leave a clear imprint in the palm of your hand.

⚠ WARNING: Securely clamping the wheel takes considerable force. If you can fully close the quick release without wrapping your fingers around the fork blade for leverage, and the lever does not leave a clear imprint in the palm of your hand, the tension is insufficient. Open the lever, turn the tension adjusting nut clockwise a quarter turn, then try again.

(5) If the lever cannot be pushed all the way to a position parallel to the fork blade, return the lever to the OPEN position. Then turn the tension adjusting nut counter clockwise one-quarter turn and try tightening the lever again.

(6) Re-engage the brake quick-release mechanism to restore correct brake pad-to-rim clearance; spin the wheel to make sure that it is centered in the frame and clears the brake pads; then squeeze the brake lever and make sure that the brakes are operating correctly.

c. Removing a Quick Release Rear Wheel

- (1) Shift the rear derailleur to high gear (the smallest, outermost rear sprocket).
- (2) If your bike has rim brakes, disengage the brake's quick-release mechanism to increase the clearance between the wheel rim and the brake pads (see Section 4.C, figs. 12 through 13).
- (3) Pull the derailleur body back with your right hand.
- (4) Move the quick-release lever to the OPEN position (fig. 7).
- (5) Lift the rear wheel off the ground a few inches and, with the derailleur still pulled back, push the wheel forward and down until it comes out of the rear dropouts.

d. Installing a Quick Release Rear Wheel

NOTE: If your bike is equipped with disk brakes, be careful not to damage the disc, caliper or brake pads when re-inserting the disk into the caliper. Never activate a disk brake's control lever unless the disk is correctly inserted in the caliper.

- (1) Make sure that the rear derailleur is still in its outermost, high gear, position.
- (2) Pull the derailleur body back with your right hand.
- (3) Move the quick-release lever to the OPEN position (see fig. 5). The lever should be on the side of the wheel opposite the derailleur and freewheel sprockets.
- (4) Put the chain on top of the smallest freewheel sprocket. Then, insert the wheel up and back into the frame dropouts and pull it all the way in to the dropouts.
- (5) Tighten the quick-release adjusting nut until it is finger tight against the frame dropout, then swing the lever toward the front of the bike until it is parallel to the frame's chainstay or seatstay and is curved toward the wheel (fig. 6 & fig. 8). To apply enough clamping force, you should have to wrap your fingers around a frame tube for leverage, and the lever should leave a clear imprint in the palm of your hand.

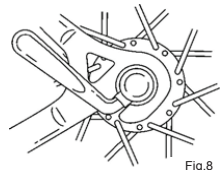

⚠ WARNING: Securely clamping the wheel takes considerable force. If you can fully close the quick release without wrapping your fingers around the seatstay or chainstay for leverage, and the lever does not leave a clear imprint in the palm of your hand, the tension is insufficient. Open the lever, turn the tension adjusting nut clockwise a quarter turn, then try again.

⚠ The rear wheel must be secured to the bicycle frame with sufficient force so that it cannot be pulled forward by the chain, even under the greatest pedaling force. If the wheel moves under pedaling force, the tire can touch the frame, which can cause you to lose control and fall.

- (6) If the lever cannot be pushed all the way to a position parallel to the chainstay or seatstay tube, return the lever to the OPEN position. Then turn the adjusting nut counterclockwise one-quarter turn and try tightening again.
- (7) Push the rear derailleur back into position.

(8) Re-engage the brake quick-release mechanism to restore correct brake pad-to-rim clearance; spin the wheel to make sure that it is centered in the frame and clears the brake pads; then squeeze the brake lever and make sure that the brakes are operating correctly.

3. Removing and Installing Bolt-On Wheels (See Appendix A)

a. Removing a Bolt-On Front Wheel

(1) If your bike has rim brakes, disengage the brake's quick-release mechanism to increase the clearance between the tire and the brake pads (see Section 4.C, figs.12 through 13).

(2) Using a correct size wrench, loosen the two axle nuts.

(3) If your front fork has a clip-on type secondary retention device, disengage it and go to the next step. If your front fork has an integral secondary retention device, loosen the axle nuts enough to allow wheel removal, then go to the next step.

(4) Raise the front wheel a few inches off the ground and tap the top of the wheel with the palm of your hand to knock the wheel out of the fork ends.

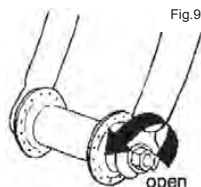

b. Installing a Bolt-On Front Wheel

(1) With the steering fork facing forward, insert the wheel between the fork blades so that the axle seats firmly at the top of the slots which are at the tips of the fork blades. The axle nut washers should be on the outside, between the fork blade and the axle nut. If your bike has a clip-on type secondary retention device, engage it.

(2) While pushing the wheel firmly to the top of the slots in the fork dropouts, and at the same time centering the wheel rim in the fork, use the correct size wrench to tighten the axle nuts enough so that the wheel stays in place; then use a wrench on each nut simultaneously to tighten the nuts as tight as you can.

(3) Re-engage the brake quick-release mechanism to restore correct brake pad-to-rim clearance; spin the wheel to make sure that it is centered in the frame and clears the brake pads; then squeeze the brake lever and make sure that the brakes are operating correctly.

c. Removing a Bolt-On Rear Wheel

⚠ WARNING: If your bike is equipped with an internal gear rear hub, do not attempt to remove the rear wheel. The removal and re-installation of internal gear hubs require special knowledge. Incorrect removal or assembly can result in hub failure, which can cause you to lose control and fall.

(1) If your bike has rim brakes, disengage the brake's quick-release mechanism to open the clearance between the tire and the brake pads (see Section 4.C, figs. 12 through 13).

(2) Shift the rear derailleur to high gear (the smallest rear sprocket) and pull the derailleur body back with your right hand.

(3) Using the correct size wrench, loosen the two axle nuts.

(4) Lift the rear wheel off the ground a few inches and, with the derailleur still pulled back, push the wheel forward and down until it comes out of the rear dropouts.

d. Installing a Bolt-On Rear Wheel

(1) Shift the rear derailleur to its outermost position and pull the derailleur body back with your right hand.

(2) Put the chain on to the smallest sprocket. Then, insert the wheel into the frame dropouts and pull it up and back completely in to the dropouts. The axle nut washers should be on the outside, between the frame and the axle nut.

(3) Using the correct size wrench, tighten the axle nuts enough so that the wheel stays in place; then use a wrench on each nut simultaneously to tighten the nuts as tight as you can.

(4) Push the rear derailleur back into position.

(5) Re-engage the brake quick-release mechanism to restore correct brake pad-to-rim clearance; spin the wheel to make sure that it is centered in the frame and clears the brake pads; then squeeze the brake lever and make sure that the brakes are operating correctly.

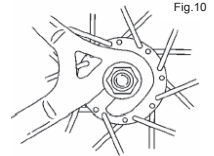

Bolt-on Rear Wheel in Dropouts

B. Seatpost quick release

Some bikes are equipped with a quick-release seat post binder. The seatpost quick-release binder works exactly like the wheel quick-release (Section 4.A.1)

While a quick release looks like a long bolt with a lever on one end and a nut on the other, the quick release uses a cam action to firmly clamp the seat post (see fig. 5).

⚠ WARNING: Riding with an improperly tightened seat post can allow the saddle to turn or move and cause you to lose control and fall. Therefore:

1. Ask a bicycle specialist to help you make sure you know how to correctly clamp your seat post.

2. Understand and apply the correct technique for clamping your seat post quick release.

3. Before you ride the bike, first check that the seatpost is securely clamped.

Adjusting the seatpost quick release mechanism

The action of the quick release cam squeezes the seat collar around the seat post to hold the seat post securely in place. The amount of clamping force is controlled by the tension adjusting nut. Turning the tension adjusting nut clockwise while keeping the cam lever from rotating increases clamping force; turning it counterclockwise

while keeping the cam lever from rotating reduces clamping force. Less than half a turn of the tension adjusting nut can make the difference between safe and unsafe clamping force.

⚠ WARNING: The full force of the cam action is needed to clamp the seatpost securely. Holding the nut with one hand and turning the lever like a wing nut with the other hand until everything is as tight as you can get it will not clamp the seatpost safely.

⚠ WARNING: If you can fully close the quick release without wrapping your fingers around the seat post or a frame tube for leverage, and the lever does not leave a clear imprint in the palm of your hand, the tension is insufficient. Open the lever, turn the tension adjusting nut clockwise a quarter turn, then try again.

C. Brakes See Appendix A (Video guides are available on Shop Talk at www.northrockbikes.com)

⚠ WARNING:

1. Riding with improperly adjusted brakes or worn brake pads is dangerous and can result in serious injury or death.
2. Applying brakes too hard or too suddenly can lock up a wheel, which could cause you to lose control and fall. Sudden or excessive application of the front brake may pitch the rider over the handlebars, which may result in serious injury or death.
3. Some bicycle brakes, such as disc brakes (fig. 11) are extremely powerful. Take extra care to become familiar with these brakes and exercise particular care when using them.

fig. 11



4. Disc brakes can get extremely hot with extended use. Be careful not to touch a disc brake until it has had plenty of time to cool.
5. See the brake manufacturer's instructions for operation and care of your brakes. If you do not have the manufacturer's instructions, see the enclosed manufacturer instructions or contact them directly.

1. Brake controls and features

It's very important to your safety that you learn and remember which brake lever controls which brake on your bike.

Make sure that your hands can reach and squeeze the brake levers comfortably. If your hands are too small to operate the levers comfortably, consult a bicycle specialist before riding the bike. The lever reach may be adjustable; or you may need a different brake lever design.

Most brakes have some form of quick-release mechanism to allow the brake to open and close. When quick-release mechanism is in the open position brakes are inoperable. Ask a bicycle specialist to make sure that you understand the way the brake quick release works on your bike (see figs. 12, 13) and check each time to make sure both brakes work correctly before you get on the bike.

Bicycles with coaster brakes typically do not have brake levers. Brakes will engage by the rider pedaling backwards. If the chain comes off the bicycle, the brakes will not work. Check chain tension before every ride.

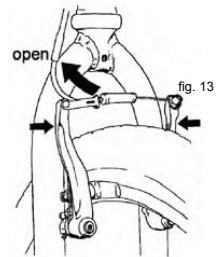
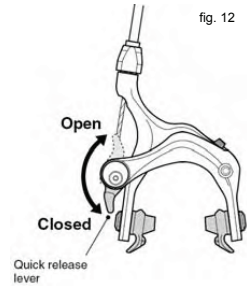

2. How brakes work

The braking action of a bicycle is a function of the pads and the wheel rim. To make sure that you have maximum friction available, keep your wheel rims and brake pads clean and free of dirt, lubricants, waxes or polishes.

Brakes are designed to control your speed, not just to stop the bike. Maximum braking force for each wheel occurs at the point just before the wheel "locks up" (stops rotating) and starts to skid. Once the tire skids, you actually lose most of your stopping force and all directional control. You need to practice slowing and stopping smoothly without locking up a wheel. The technique is called progressive brake modulation. Instead of jerking the brake lever to the position where you think you'll generate appropriate braking force, squeeze the lever, progressively increasing the braking force. If you feel the wheel begin to lock up, release pressure just a little to keep the wheel rotating just short of lockup. It's important to develop a feel for the amount of brake lever pressure required for each wheel at different speeds and on different surfaces. To better understand this, experiment a little by walking your bike and applying different amounts of pressure to each brake lever, until the wheel locks.

When you apply one or both brakes, the bike begins to slow, but your body wants to continue at the speed at which it was going. This causes a transfer of weight to the front wheel (or, under heavy braking, around the front wheel hub, which could send you flying over the handlebars). A wheel with more weight on it will accept greater brake pressure before lockup; a wheel with less weight will lock up with less brake pressure. So, as you apply brakes and your weight is transferred forward, you need to shift your body toward the rear of the bike, to transfer weight back on to the rear wheel; and at the same time, you need to both decrease rear braking and increase front braking force. This is even more important on descents, because descents shift weight forward.

Two keys to effective speed control and safe stopping are controlling wheel lockup and weight transfer. This weight transfer is even more pronounced if your bike has a front suspension fork. Front suspension “dips” under braking, increasing the weight transfer (see also Section 4.G). Practice braking and weight transfer techniques where there is no traffic or other hazards and distractions.

Everything changes when you ride on loose surfaces or in wet weather. Tire adhesion is reduced, so the wheels have less cornering and braking traction and can lock up with less brake force. Moisture or dirt on the brake pads reduces their ability to grip. The way to maintain control on loose or wet surfaces is to go more slowly to begin with.

D. Shifting gears

Your multi-speed bicycle will have a derailleur drivetrain, an internal gear hub drivetrain or, in some special cases, a combination of the two.

1. How a derailleur drivetrain works

If your bicycle has a derailleur drivetrain, the gear-changing mechanism will have:

- a rear cassette or freewheel sprocket cluster
- a rear derailleur
- usually a front derailleur
- one or two shifters
- one, two or three front sprockets called chainrings
- a drive chain

a. Shifting gears

There are several different types and styles of shifting controls: levers, twist grips, triggers, combination shift/brake controls and push-buttons. Ask a bicycle specialist to explain the type of shifting controls that are on your bike, and to show you how they work.

The vocabulary of shifting can be pretty confusing. A downshift is a shift to a “lower” or “slower” gear, one which is easier to pedal. An upshift is a shift to a “higher” or “faster”, harder to pedal gear. What’s confusing is that what’s happening at the front derailleur is the opposite of what’s happening at the rear derailleur (for details, read the instructions on Shifting the Rear Derailleur and Shifting the Front Derailleur below). For example, you can select a gear which will make pedaling easier on a hill (make a downshift) in one of two ways: shift the chain down the gear “steps” to a smaller gear at the front, or up the gear “steps” to a larger gear at the rear. So, at the rear gear cluster, what is called a downshift looks like an upshift. The way to keep things straight is to remember that shifting the chain in towards the centerline of the bike is for accelerating and climbing and is called a downshift. Moving the chain out or away from the centerline of the bike is for speed and is called an upshift. Whether upshifting or downshifting, the bicycle derailleur system design requires that the drive chain be moving forward and be under at least some tension. A derailleur will shift only if you are pedaling forward.

 **CAUTION: Never move the shifter while pedaling backward, nor pedal backwards immediately after having moved the shifter. This could jam the chain and cause serious damage to the bicycle.**

b. Shifting the rear derailleur

The rear derailleur is controlled by the right shifter.

The function of the rear derailleur is to move the drive chain from one gear sprocket to another. The smaller sprockets on the gear cluster produce higher gear ratios. Pedaling in the higher gears requires greater pedaling effort, but takes you a greater distance with each revolution of the pedal cranks. The larger sprockets produce lower gear ratios. Using them requires less pedaling effort, but takes you a shorter distance with each pedal crank revolution. Moving the chain from a smaller sprocket of the gear cluster to a larger sprocket results in a downshift. Moving the chain from a larger sprocket to a smaller sprocket results in an upshift. In order for the derailleur to move the chain from one sprocket to another, the rider must be pedaling forward.

c. Shifting the front derailleur

The front derailleur, which is controlled by the left shifter, shifts the chain between the larger and smaller chainrings. Shifting the chain onto a smaller chainring makes pedaling easier (a downshift). Shifting to a larger chainring makes pedaling harder (an upshift).

d. Which gear should I be in?

The combination of largest rear and smallest front gears (fig. 14) is for the steepest hills. The smallest rear and largest front combination is for the greatest speed. It is not necessary to shift gears in sequence. Instead, find the “starting gear” which is right for your level of ability—a gear which is hard enough for quick acceleration but easy enough to let you start from a stop without wobbling -and experiment with upshifting and downshifting to get a feel for the different gear combinations. At first, practice shifting where there are no obstacles, hazards or other traffic, until you’ve built up your confidence. Learn to anticipate the need to shift, and shift to a lower gear before the hill gets too steep. If you have difficulties with shifting, the problem could be mechanical adjustment. See a bicycle specialist for help.

⚠ WARNING: Never shift a derailleur onto the largest or the smallest sprocket if the derailleur is not shifting smoothly. The derailleur may be out of adjustment and the chain could jam, causing you to lose control and fall.

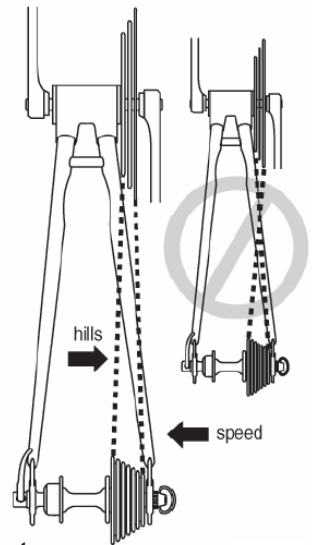

Fig.14

2. How an internal gear hub drivetrain works

If your bicycle has an internal gear hub drivetrain, the gear changing mechanism will consist of:

- a 3, 5, 7, 8 or possibly 12 speed internal gear hub
- one, or sometimes two shifters
- one or two control cables
- one front sprocket called a chainring

a. Shifting internal gear hub gears

Shifting with an internal gear hub drivetrain is simply a matter of moving the shifter to the indicated position for the desired gear. After you have moved the shifter to the gear position of your choice, ease the pressure on the pedals for an instant to allow the hub to complete the shift.

b. Which gear should I be in?

The numerically lowest gear (1) is for the steepest hills. The numerically largest gear (3, 5, 7 or 12, depending on the number of speeds of your hub) is for the greatest speed. Shifting from an easier, “slower” gear (like 1) to a harder, “faster” gear (like 2 or 3) is called an upshift. Shifting from a harder, “faster” gear to an easier, “slower” gear is called a downshift. It is not necessary to shift gears in sequence. Instead, find the “starting gear” for the conditions — a gear which is hard enough for quick acceleration but easy enough to let you start from a stop without wobbling — and experiment with upshifting and downshifting to get a feel for the different gears. At first, practice shifting where there are no obstacles, hazards or other traffic, until you’ve built up your confidence. Learn to anticipate the need to shift, and shift to a lower gear before the hill gets too steep. If you have difficulties with shifting, the problem could be mechanical adjustment. See a bicycle specialist for help.

E. Derailleur adjustment-how to

(Video guides are available on Shop Talk at www.northrockbikes.com)



Although the front and rear derailleurs are initially adjusted at the factory, you may need to inspect and readjust before riding the bicycle. A bicycle specialist can assist.

Note: Before attempting adjustments see the manufacturer’s instructions or consult a bicycle specialist.

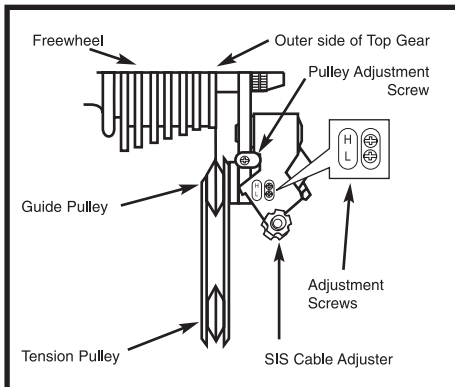

For additional assistance visit Northrock Shop Talk, scan here:



Rear Derailleur

Begin by shifting the rear shifter to largest number indicated, disconnect the cable from the rear derailleur cable anchor bolt, and place the chain on the smallest sprocket. Adjust the **High** limit screw so the guide pulley and the smallest sprocket are lined up vertically. Reconnect the cable, pull out any slack, and retighten the anchor bolt securely. Shift through the gears, making sure each gear achieved is done quietly and without hesitation. If necessary, use the barrel adjuster to fine tune each gear by turning it the direction you want the chain to go. For example, turning clockwise will loosen the cable tension and move the chain away from the wheel, while turning counter-clockwise will tighten cable tension and direct the chain towards the wheel. Shift the rear shifter to the gear one and place the chain on the largest cog. Adjust the **Low** limit screw in quarter turn increments until the guide pulley and the largest cog are aligned vertically. Again, shift through each gear several times, checking that each gear is achieved smoothly. It may take several attempts before the rear derailleur and cable is adjusted properly.

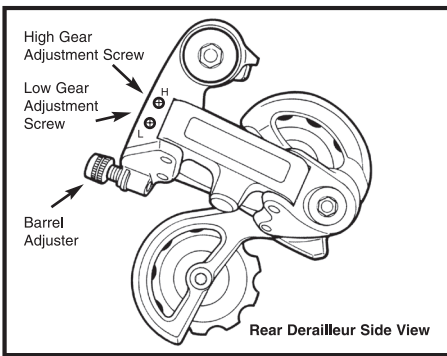

Ensure all bolts are secured tightly and the chain does not fall off in either direction.

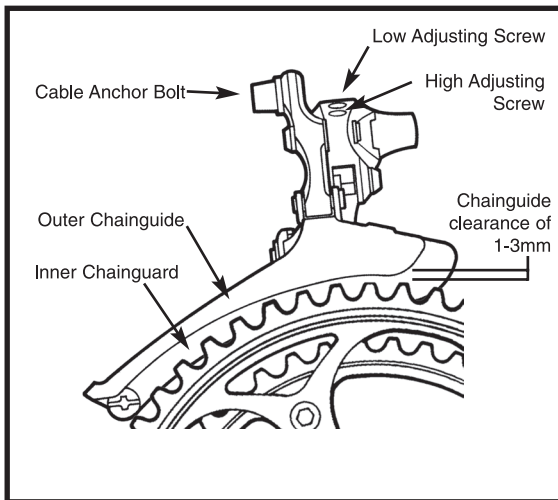

Front Derailleur

Shift both shifters to the smallest number indicated and place the chain on the corresponding cog and chainwheel. Disconnect the front derailleur cable from the cable anchor bolt. Check the position of the front derailleur; it should be parallel with the outer chainwheel and clear the largest chainwheel by 1-3mm when fully engaged.

With the chain on the smallest chainwheel in front and the largest cog in back, adjust the “Low” limit screw so the chain is centered in the front derailleur cage.

Reconnect the cable, pull any slack out, and tighten the anchor bolt securely.

Shift the front shifter to the largest chainwheel. If the chain does not go onto the largest chainwheel, turn the “High” limit screw in 1/4 turn increments counter-clockwise until the chain engages the largest chainwheel. If the chain falls off the largest chainwheel, and into the pedals, you will need to turn the “High” limit screw in 1/4 turn increments clockwise until the chain no longer falls off. Shift through every gear, using the barrel adjusters to fine tune each transition. The barrel adjuster for the front derailleur is located on the front shifter where the cable comes out of the shifter. Clockwise will loosen the cable tension and direct the chain closer to the frame while counter-clockwise will tighten the cable tension and direct the chain away from the frame.



Do not ride a bicycle that is not shifting properly. Overlooking proper adjustments may cause irreparable damage to the bicycle and/or bodily injury. Never move the shifter while pedaling backward, nor pedal backwards after having moved the shifter.

This could jam the chain and cause serious damage to the bicycle and/or rider.

F. Pedals

1. Toe overlap is when your toe can touch the front wheel when you turn the handlebars to steer while a pedal is in the forward most position. This is common on small-framed bicycles, and is avoided by keeping the inside pedal up and the outside pedal down when making sharp turns. On any bicycle, this technique will also prevent the inside pedal from striking the ground in a turn.



WARNING: Toe overlap could cause you to lose control and fall. Ask a bicycle specialist to help you determine if the combination of frame size, crank arm length, pedal design and shoes you will use results in pedal overlap. Whether you have overlap or not, you must keep the inside pedal up and the outside pedal down when making sharp turns.

Pedal Assembly: See included instructions for proper pedal assembly: To avoid stripping, make sure threads are aligned and tight to crank.



2. Some bicycles come equipped with pedals that have sharp and potentially dangerous surfaces. These surfaces are designed to add safety by increasing grip between the rider's shoe and the pedal. If your bicycle has this type of high-performance pedal, you must take extra care to avoid serious injury from the pedals' sharp surfaces. Based on your riding style or skill level, you may prefer a less aggressive pedal design, or choose to ride with shin pads. A bicycle specialist can show you a number of options and make suitable recommendations.

3. Toeclips and straps are a means to keep feet correctly positioned and engaged with the pedals. The toeclip positions the ball of the foot over the pedal spindle, which gives maximum pedaling power. The toe strap, when tightened, keeps the foot engaged throughout the rotation cycle of the pedal. While toeclips and straps give some benefit with any kind of shoe, they work most effectively with cycling shoes designed for use with toeclips. A bicycle specialist can explain how toeclips and straps work. Shoes with deep treaded soles or welts which might make it more difficult for you to remove your foot should not be used with toeclips and straps.

⚠ WARNING: Getting into and out of pedals with toeclips and straps requires skill which can only be acquired with practice. Until it becomes a reflex action, the technique requires concentration which can distract your attention and cause you to lose control and fall. Practice the use of toeclips and straps where there are no obstacles, hazards or traffic. Keep the straps loose, and don't tighten them until your technique and confidence in getting in and out of the pedals warrants it. Never ride in traffic with your toe straps tight.

4. Clipless pedals (sometimes called "step-in pedals") are another means to keep feet securely in the correct position for maximum pedaling efficiency. They have a plate, called a "cleat," on the sole of the shoe, which clicks into a mating spring-loaded fixture on the pedal. They only engage or disengage with a very specific motion which must be practiced until it becomes instinctive. Clipless pedals require shoes and cleats which are compatible with the make and model pedal being used.

Many clipless pedals are designed to allow the rider to adjust the amount of force needed to engage or disengage the foot. Follow the pedal manufacturer's instructions, or ask a bicycle specialist to show you how to make this adjustment. Use the easiest setting until engaging and disengaging becomes a reflex action, but always make sure that there is sufficient tension to prevent unintended release of your foot from the pedal.

⚠ WARNING: Clipless pedals are intended for use with shoes specifically made to fit them and are designed to firmly keep the foot engaged with the pedal. Using shoes which do not engage the pedals correctly is dangerous.

Practice is required to learn to engage and disengage the foot safely. Until engaging and disengaging the foot becomes a reflex action, the technique requires concentration which can distract your attention and cause you to lose control and fall. Practice engaging and disengaging clipless pedals in a place where there are no obstacles, hazards or traffic; and be sure to follow the pedal manufacturer's setup and service instructions. If you do not have the manufacturer's instructions, see a bicycle specialist or contact the manufacturer.

G. Bicycle suspension

Many bicycles are equipped with suspension systems. There are many different types of suspension systems — too many to deal with individually in this Manual. If your bicycle has a suspension system of any kind, be sure to read and follow the suspension manufacturer's setup and service instructions. If you do not have the manufacturer's instructions, see a bicycle specialist or contact the manufacturer.

 WARNING: Failure to maintain, check and properly adjust the suspension system may result in suspension malfunction, which may cause you to lose control and fall.

If your bike has suspension, the increased speed you may develop also increases your risk of injury. For example, when braking, the front of a suspended bike dips. You could lose control and fall if you do not have experience with this system. Learn to handle your suspension system safely. See also Section 4.C.

 WARNING: Changing suspension adjustment can change the handling and braking characteristics of your bicycle. Never change suspension adjustment unless you are thoroughly familiar with the suspension system manufacturer's instructions and recommendations, and always check for changes in the handling and braking characteristics of the bicycle after a suspension adjustment by taking a careful test ride in a hazard-free area.

Suspension can increase control and comfort by allowing the wheels to better follow the terrain. This enhanced capability may allow you to ride faster, but you must not confuse the enhanced capabilities of the bicycle with your own capabilities as a rider. Increasing your skill will take time and practice. Proceed carefully until you have learned to handle the full capabilities of your bike.

 CAUTION: Not all bicycles can be safely retrofitted with some types of suspension systems. Before retrofitting a bicycle with any suspension, check with the bicycle's manufacturer or a specialist to make sure that what you want to do is compatible with the bicycle's design.

H. Tires and tubes

1. Tires

Bicycle tires are available in many designs and specifications, ranging from general-purpose designs to tires designed to perform best under very specific weather or terrain conditions. If, once you've gained experience with your new bike, you feel that a different tire might better suit your riding needs, a bicycle specialist can help you select the most appropriate design.

The size, pressure rating, and on some high-performance tires the specific recommended use, are marked on the sidewall of the tire (see fig. 15). The part of this information which is most important to you is Tire Pressure.

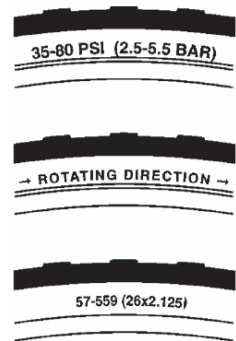

Tire markings

Fig.15

⚠ WARNING: Never inflate a tire beyond the maximum pressure marked on the tire's sidewall. Exceeding the recommended maximum pressure may blow the tire off the rim, which could cause damage to the bike and injury to the rider and bystanders.

The best and safest way to inflate a bicycle tire to the correct pressure is with a bicycle pump which has a built-in pressure gauge.

⚠ WARNING: There is a safety risk in using gas station air hoses or other air compressors. They are not made for bicycle tires. They move a large volume of air very rapidly, and will raise the pressure in your tire very rapidly, which could cause the tube to explode.

Tire pressure is given either as maximum pressure or as a pressure range. How a tire performs under different terrain or weather conditions depends largely on tire pressure. Inflating the tire to near its maximum recommended pressure gives the lowest rolling resistance; but also produces the harshest ride. High pressures work best on smooth, dry pavement.

Very low pressures, at the bottom of the recommended pressure range, give the best performance on smooth, slick terrain such as hard-packed clay, and on deep, loose surfaces such as deep, dry sand.

Tire pressure that is too low for your weight and the riding conditions can cause a puncture of the tube by allowing the tire to deform sufficiently to pinch the inner tube between the rim and the riding surface.

⚠ CAUTION: Pencil-type automotive tire gauges can be inaccurate and should not be relied upon for consistent, accurate pressure readings. Instead, use a high quality dial gauge.

Ask a bicycle specialist to recommend the best tire pressure for the kind of riding you will most often do, and have the bicycle specialist inflate your tires to that pressure. Then, check inflation as described in Section 1.C so you'll know how correctly inflated tires should look and feel when you don't have access to a gauge. Some tires may need to be brought up to pressure every week or two.

Some special high-performance tires have unidirectional treads: their tread pattern is designed to work better in one direction than in the other. The sidewall marking of a unidirectional tire will have an arrow showing the correct rotation direction. If your bike has unidirectional tires, be sure that they are mounted to rotate in the correct direction.

2. Tire Valves

There are primarily three kinds of bicycle tube valves: The Schraeder Valve, the Presta Valve and the Woods/Dunlop valve. The bicycle pump you use must have the fitting appropriate to the valve stems on your bicycle.

The Schraeder valve (fig. 16) is like the valve on a car tire. To inflate a Schraeder valve tube, remove the valve cap and clamp the pump fitting onto the end of the valve stem. To let air out of a Schraeder valve, depress the pin in the end of the valve stem with the end of a key or other appropriate object.

The Presta valve (fig. 16) has a narrower diameter and is only found on bicycle tires. To inflate a Presta valve tube using a Presta headed bicycle pump, remove the valve cap; unscrew (counterclockwise) the valve stem lock nut; and push down on the valve stem to free it up. Then push the pump head on to the valve head, and inflate. To inflate a Presta valve with a Schraeder pump fitting, you'll need a Presta adapter (available at a bike shop) which screws on to the valve stem once you've freed up the valve. The adapter fits into the Schraeder pump fitting. Close the valve after inflation. To let air out of a Presta valve, open up the valve stem lock nut and depress the valve stem.

There is a third type of valve, which has a bottom similar to a Schrader and necks down to about the size of a Presta. This is a Woods valve, also known as a "Dunlop" valve. You can pump them up with a Presta pump.



Woods/Dunlop valve

Presta valve

Schraeder valve

⚠ WARNING: Patching a tube is an emergency repair. If you do not apply the patch correctly or apply several patches, the tube can fail, resulting in possible tube failure, which could cause you to lose control and fall. Replace a patched tube as soon as possible.

5. Fit

NOTE: Correct fit is an essential element of bicycling safety, performance and comfort. Making the adjustments to your bicycle which result in correct fit for your body and riding conditions requires experience, skill and special tools. Always have a bicycle specialist make the adjustments on your bicycle; or, if you have the experience, skill and tools, have a bicycle specialist check your work before riding.

⚠ WARNING: If your bicycle does not fit properly, you may lose control and fall.

A. Standover height

Standover height is the basic element of bike fit (see fig. 2). It is the distance from the ground to the top of the bicycle's frame at that point where your crotch is when straddling the bike. To check for correct standover height, straddle the bike while

fig.2



wearing the kind of shoes in which you'll be riding, and bounce vigorously on your heels. If your crotch touches the frame, the bike is too big for you. Don't even ride the bike around the block. A bike which you ride only on paved surfaces and never take off-road should give you a minimum standover height clearance of two inches (5 cm). A bike that you'll ride on unpaved surfaces should give you a minimum of three inches (7.5 cm) of standover height clearance. And a bike that you'll use off road should give you four inches (10 cm) or more of clearance.

⚠ WARNING: If you plan to use your bike for jumping or stunt riding despite our advice not to, read Section 2.F again.

B. Saddle position

Correct saddle adjustment is an important factor in getting the most performance and comfort from your bicycle. If the saddle position is not comfortable for you, consult a bicycle specialist.

The saddle can be adjusted in three directions:

1. Up and down adjustment. To check for correct saddle height (fig. 3):
 - sit on the saddle;
 - place one heel on a pedal;
 - rotate the crank until the pedal with your heel on it is in the down position and the crank arm is parallel to the seat tube.

fig.3

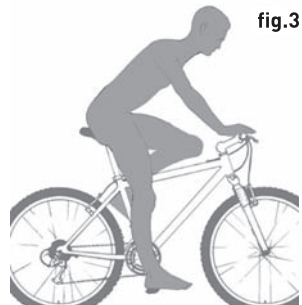

If your leg is not completely straight, your saddle height needs to be adjusted. If your hips must rock for the heel to reach the pedal, the saddle is too high. If your leg is bent at the knee with your heel on the pedal, the saddle is too low.

Once the saddle is at the correct height, make sure that the seatpost does not project from the frame beyond its “Minimum Insertion” or “Maximum Extension” mark. (see fig. 4).

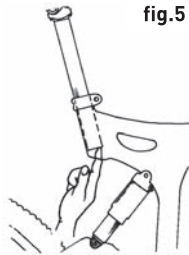
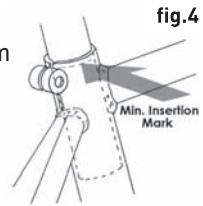

If your bike has an interrupted seat tube, as is the case on some bikes with rear suspension, you must also make sure that the seat post is far enough into the frame so that you can touch it through the bottom of the interrupted seat tube with the tip of your finger without inserting your finger beyond its first knuckle. (see fig. 5).

⚠ WARNING: If your seat post projects from the frame beyond the Minimum Insertion or Maximum Extension mark (see fig. 4) or you cannot touch the bottom of the seat post through the bottom of the interrupted seat tube with the tip of your finger without inserting your finger beyond its first knuckle (see fig.5), the seat post may break, which could cause you to lose control and fall.

2. Front and back adjustment. The saddle can be adjusted forward or back to help you get the optimal position on the bike. Ask a bicycle specialist to set the saddle for your optimal riding position and to show you how to make this adjustment.

3. Saddle angle adjustment. Most people prefer a horizontal saddle, but some riders like the saddle nose angled up or down just a little. A bicycle specialist can adjust saddle angle or teach you how to do it.

Note: If your bicycle is equipped with a suspension seat post, periodically ask a bicycle specialist to check it.

Small changes in saddle position can have a substantial effect on performance and comfort. To find your best saddle position, make only one adjustment at a time.

⚠ WARNING: After any saddle adjustment, be sure that the saddle adjusting mechanism is properly tightened before riding. A loose saddle clamp or seat post binder can cause damage to the seat post, or can cause you to lose control and fall. A correctly tightened saddle adjusting mechanism will allow no saddle movement in any direction. Periodically check to make sure that the saddle adjusting mechanism is properly tightened.

If, in spite of carefully adjusting the saddle height, tilt and fore-and-aft position, your saddle is still uncomfortable, you may need a different saddle design. Saddles, like people, come in many different shapes, sizes and resilience. A bicycle specialist can help you select a saddle which, when correctly adjusted for your body and riding style, will be comfortable.

⚠ WARNING: Some people have claimed that extended riding with a saddle which is incorrectly adjusted or which does not support your pelvic area correctly can cause short-term or long-term injury to nerves and blood vessels, or even impotence. If your saddle causes you pain, numbness or other discomfort, listen to your body and stop riding until you see a bicycle specialist about saddle adjustment or a different saddle.

C. Handlebar height and angle

Your bike is equipped either with a “threadless” stem, which clamps on to the outside of the steerer tube, or with a “quill” stem, which clamps inside the steerer tube by way of an expanding binder bolt. If you aren’t absolutely sure which type of stem your bike has, ask a qualified specialist.

If your bike has a “threadless” stem, a qualified specialist may be able to change handlebar height by moving height adjustment spacers from below the stem to above the stem, or vice versa. Otherwise, you’ll have to get a stem of different length or rise. Consult a qualified specialist. Do not attempt to do this yourself, as it requires special knowledge.

If your bike has a “quill” stem, you can ask a bicycle specialist to adjust the handlebar height a bit by adjusting stem height.

A quill stem has an etched or stamped mark on its shaft which designates the stem’s “Minimum Insertion” or “Maximum Extension”. This mark must not be visible above the headset.

⚠ WARNING: On some bicycles, changing the stem or stem height can affect the tension of the front brake cable, locking the front brake or creating excess cable slack which can make the front brake inoperable. If the front brake pads move in towards the wheel rim or out away from the wheel rim when the stem or stem height is changed, the brakes must be correctly adjusted before you ride the bicycle.

⚠ WARNING: The stem’s Minimum Insertion Mark must not be visible above the top of the headset. If the stem is extended beyond the Minimum Insertion Mark the stem may break or damage the fork’s steerer tube, which could cause you to lose control and fall.

A qualified specialist can also change the angle of the handlebar or bar end extension.

⚠ WARNING: An insufficiently tightened stem binder bolt, handlebar binder bolt or bar end extension clamping bolt may compromise steering action, which could cause you to lose control and fall. Place the front wheel of the bicycle between your legs and attempt to twist the handlebar/stem assembly. If you can twist the stem in relation to the front wheel, turn the handlebars in relation to the stem, or turn the bar end extensions in relation to the handlebar, the bolts are insufficiently tightened.

D. Control position adjustments

The angle of the brake and shift control levers and their position on the handlebars can be changed. Ask a bicycle specialist to make the adjustments for you.

E. Brake reach

Many bikes have brake levers which can be adjusted for reach. If you have small hands or find it difficult to squeeze the brake levers, see the manufacturer instructions for adjusting the reach or fit shorter reach brake levers.

F. Stem and handlebar adjustment

Note: Threadless stems do not adjust. To change your riding position, consult a bike specialist for a *threadless stem extender* or *threadless adjustable stem*, the size is 1-1/8 in. Only the CL5 and SC7 comfort models quill stem adjust.

For information on making stem and handlebar adjustments visit the FAQ page and/or Shop Talk at www.northrockbikes.com, or scan here:



⚠ WARNING: The shorter the brake lever reach, the more critical it is to have correctly adjusted brakes, so that full braking power can be applied within available brake lever travel. Brake lever travel insufficient to apply full braking power can result in loss of control, which may result in serious injury or death.

7. Service

⚠ WARNING: Technological advances have made bicycles and bicycle components more complex, and the pace of innovation is increasing. It is impossible for this manual to provide all the information required to properly repair and/or maintain your bicycle. In order to help minimize the chances of an accident and possible injury, it is critical that you have any repair or maintenance which is not specifically described in this manual performed by a qualified bicycle specialist. Equally important is that your individual maintenance requirements will be determined by everything from your riding style to geographic location. Consult bicycle specialist for help in determining your maintenance requirements.

⚠ WARNING: Many bicycle service and repair tasks require special knowledge and tools. Do not begin any adjustments or service on your bicycle until you have learned from a qualified bicycle specialist how to properly complete them. Improper adjustment or service may result in damage to the bicycle or in an accident which can cause serious injury or death.

If you want to learn to do major service and repair work on your bike, you have three options:

1. Consult for guidance with a qualified bicycle specialist.
2. Ask a qualified bicycle specialist to recommend a book on bicycle repair.
3. Ask a qualified bicycle specialist about the availability of bicycle repair courses in your area.

Regardless of which option you select, we recommend that you ask a bicycle specialist to check the quality of your work the first time you work on something and before you ride the bike, just to make sure that you did everything correctly. Since that will require the time of a mechanic, there may be a modest charge for this service.

A. Service intervals

Some service and maintenance can and should be performed by the owner, and require no special tools or knowledge beyond what is presented in this manual.

The following are examples of the type of service you should perform yourself. All other service, maintenance and repair should be performed by a mechanic using the correct tools and procedures specified by the manufacturer.

1. Break-in Period: Your bike will last longer and work better if you break it in before riding it hard. Control cables and wheel spokes may stretch or “seat” when a new bike is first used and may require readjustment by a bicycle specialist.

Your Mechanical Safety Check (Section 1.C) will help you identify some things that need readjustment. But even if everything seems fine to you, it's best to take your bike to a bicycle specialist for a 30 day checkup or three to five hours of hard off road use.

2. Before every ride: Mechanical Safety Check (Section 1.C)

3. After every long or hard ride: if the bike has been exposed to water or grit; or at least every 160 km (100 miles): Clean the bike and lightly oil the chain. Wipe off excess oil. If applicable, check headset, wheel, pedal and bottom bracket bearings are lubricated and run freely. Seek a bicycle specialist for proper maintenance and servicing.

4. After every long or hard ride or after every 10 to 20 hours of riding:

- Squeeze the front brake and rock the bike forward and back. Everything feel solid? If you feel a clunk with each forward or backward movement of the bike, you probably have a loose headset. Have a specialist check it.
- Lift the front wheel off the ground and swing it from side to side. Feel smooth? If you feel any binding or roughness in the steering, you may have a tight headset. Have a bicycle specialist check it.
- Grab one pedal and rock it toward and away from the centerline of the bike; then do the same with the other pedal. Anything feel loose? If so, have a bicycle specialist check it.
- Take a look at the brake pads. Starting to look worn or not hitting the wheel rim squarely? Time to have a qualified bicycle specialist adjust or replace them.
- Carefully check the control cables and cable housings. Any rust? Kinks? Fraying? If so, have a qualified bicycle specialist replace them.
- Squeeze each adjoining pair of spokes on either side of each wheel between your thumb and index finger. Do they all feel about the same? If any feel loose, have a qualified bicycle specialist check the wheel for tension and trueness.
- Check to make sure that all parts and accessories are still secure, and tighten any which are not.
- Check the frame, particularly in the area around all tube joints; the handlebars; the stem; and the seatpost for any deep scratches, cracks or discoloration. These are signs of stress-caused fatigue and indicate that a part is at the end of its useful life and needs to be replaced by a qualified bicycle specialist.

⚠ WARNING: Like any mechanical device, a bicycle and its components are subject to wear and stress. Different materials and mechanisms wear or fatigue from stress at different rates and have different life cycles. If a component's life cycle is exceeded, the component can suddenly and catastrophically fail, causing serious injury or death to the rider. Scratches, cracks, fraying and discoloration are signs of stress-caused fatigue and indicate that a part is at the end of its useful life and needs to be replaced. While the materials and workmanship of your bicycle or of individual components may be covered by a warranty for a specified period of time by the manufacturer, this is no guarantee that the product will last the term of the warranty. Product life is often related to the kind of riding you do and to the treatment to which you submit the bicycle. The bicycle's warranty is not meant to suggest that the bicycle cannot be broken or will last forever. It only means that the bicycle is covered subject to the terms of the warranty.

5. As required: If either brake lever fails the Mechanical Safety Check (Section 1.C), don't ride the bike. Have a qualified bicycle specialist check the brakes.

If the chain won't shift smoothly and quietly from gear to gear, the derailleur is out of adjustment. See a bicycle specialist.

6. Every 25 (hard off-road) to 50 (on-road) hours of riding: Take your bike to a qualified bicycle specialist for a complete checkup.

B. If your bicycle sustains an impact:

First, check yourself for injuries, and take care of them as best you can. Seek medical help if necessary.

Next, check your bike for damage. If see any damage, don't ride the bike until it has been repaired.

After any crash, take your bike to a qualified bicycle specialist for a thorough check.

⚠ WARNING: A crash or other impact can put extraordinary stress on bicycle components, causing them to fatigue prematurely. Components suffering from stress fatigue can fail suddenly and catastrophically, causing loss of control, serious injury or death.

⚠ CAUTION: Never use clamps on lightweight carbon composite or aluminum bicycle frames. Clamps such as those found on bicycle work stands and car racks can damage the carbon or aluminum frame.

7. Appendix A

1. How the coaster brake works

The coaster brake is a sealed mechanism which is a part of the bicycle's rear wheel hub. The brake is activated by reversing the rotation of the pedal cranks. Start with the pedal cranks in a nearly horizontal position, with the front pedal in about the 4 o'clock position, and apply downward foot pressure on the pedal that is to the rear. About 1/8 turn rotation will activate the brake. The more downward pressure you apply, the more braking force, up to the point where the rear wheel stops rotating and begins to skid. Parents should explain how the coaster brake works to a child.

WARNING: Before riding, make sure that the brake is working properly. If it is not working properly, have the bicycle checked by a bicycle specialist before you ride it.

WARNING: If your bike has only a coaster brake, ride conservatively. A single rear brake does not have the stopping power of front-and-rear brake systems.

2. Adjusting your coaster brake

Coaster brake service and adjustment requires special tools and special knowledge. Do not attempt to disassemble or service your coaster brake. Take to a bicycle specialist for coaster brake service.

Note: There are three general types of bicycle brakes: rim brakes, which operate by squeezing the wheel rim between two brake pads; disc brakes, which operate by squeezing a hub-mounted disc between two brake pads; and internal hub brakes. All three can be operated by way of a handlebar mounted lever. On some models of bicycle, the internal hub brake is operated by pedaling backwards. This is called a Coaster Brake as described above in Appendix A.

WARNING: If your bike is equipped with a hub brake such as a rear coaster brake, front or rear drum, band or roller brake; or if it has an internal gear rear hub, do not attempt to remove the wheel. The removal and re-installation of most hub brakes and internal gear hubs requires special knowledge. Incorrect removal or assembly can result in brake or gear failure, which can cause you to lose control and fall.

8. Warranty

WARRANTY INFORMATION

Northrock Bicycle, Inc. ("Northrock") warrants paint finish and all original components, and all Northrock brand repair parts, replacement parts, and accessories, are warranted to be free from defects in material or workmanship for a period of one year from the original date of purchase. All Warranty claims must be submitted to Northrock Bicycles, Inc. and must be shipped prepaid at the owners expense and accompanied by proof of purchase. The original purchaser will be responsible for any other warranty claims not included in this statement are void. This includes installation, assembly and disassembly costs.

LIMITED REMEDY

Unless otherwise provided, the sole remedy under the above warranty, or any implied warranty, is limited to the replacement of defective parts with those of equal or greater value at the sole discretion of Northrock. IN NO EVENT SHALL NORTHROCK BE RESPONSIBLE FOR DIRECT, INCIDENTAL OR CONSEQUENTIAL DAMAGES, INCLUDING, WITHOUT LIMITATION, DAMAGES FOR PERSONAL INJURY, PROPERTY DAMAGE, OR ECONOMIC LOSSES, WHETHER BASED ON CONTRACT, WARRANTY, NEGLIGENCE, PRODUCT LIABILITY, OR ANY OTHER THEORY. Some states do not allow the exclusion or limitation of damages, so the above limitation or exclusion may not apply to you.

EXCLUSIONS

THE ABOVE WARRANTY, OR ANY IMPLIED WARRANTY, DOES NOT COVER NORMAL WEAR AND TEAR. ALL WARRANTIES ARE VOID IF THE BICYCLE IS MODIFIED FROM ITS ORIGINAL CONDITION OR THE BICYCLE IS USED FOR OTHER THAN NORMAL ACTIVITIES, INCLUDING, BUT NOT LIMITED TO, FAILING TO FOLLOW THE OWNER'S MANUAL OR USING THE BICYCLE FOR COMMERCIAL ACTIVITIES OR IN COMPETITIVE EVENTS, INCLUDING BUT NOT LIMITED TO BICYCLE RACING, BICYCLE MOTOCROSS RACING, STUNT RIDING, RAMP JUMPING OR SIMILAR ACTIVITIES, AND TRAINING FOR SUCH ACTIVITIES OR EVENTS. NORTHROCK MAKES NO OTHER WARRANTIES, EXPRESS OR IMPLIED. ALL IMPLIED WARRANTIES, INCLUDING THE WARRANTIES OF MERCHANTABILITY AND FITNESS FOR A PARTICULAR PURPOSE, ARE LIMITED IN DURATION TO THAT OF THE EXPRESS WARRANTIES STATED ABOVE. Some states or provinces and territories do not allow limitations on how long an implied warranty lasts, so the above limitation may not apply to you. This warranty gives you specific legal rights, and you may also have other rights which vary from place to place.

AUSTRALIA: Our goods come with guarantees that cannot be excluded under the Australian Consumer Law. You are entitled to a replacement or refund for a major failure and for compensation for any other reasonably foreseeable loss or damage. You are also entitled to have the goods repaired or replaced if the goods fail to be of acceptable quality and the failure does not amount to a major failure.

Gear up for a great ride!

For instructional bike videos visit Northrock Shop Talk at www.northrockbikes.com.

Shop Talk



Note: Shop Talk videos are intended as a guide only and do not take the place of the official Northrock Owner's Manual and or component providers instructions.

Join the Northrock Nation of riders on Facebook to stay connected



Northrock Customer Service
For assistance, visit www.northrockbikes.com
or scan here for Support:



Distributed by:
Costco Wholesale Corporation
P.O. Box 34535
Seattle, WA 98124-1535
USA
1-800-774-2678
www.costco.com

Costco Wholesale Canada Ltd.*
415 W. Hunt Club Road
Ottawa, Ontario
K2E 1C5, Canada
1-800-463-3783
www.costco.ca
* faisant affaire au Québec sous
le nom les Entrepôts Costco

Importado por:
Importadora Primex S.A. de C.V.
Blvd. Magnocentro No. 4
San Fernando La Herradura
Huixquilucan, Estado de México
C.P. 52765
RFC: IPR-930907-S70
(55)-5246-5500
www.costco.com.mx

Costco Wholesale Australia Pty Ltd
17-21 Parramatta Road
Lidcombe NSW 2141
Australia
www.costco.com.au

Costco Wholesale UK Ltd /
Costco Online UK Ltd
Hartspring Lane
Watford, Herts
WD25 8JS
United Kingdom
01923 213113
www.costco.co.uk

Costco Wholesale Spain S.L.U.
Polígono Empresarial Los Gavilanes
C/ Agustín de Betancourt, 17
28906 Getafe (Madrid) España
NIF: B86509460
900 111 155
www.costco.es

Costco Wholesale Iceland ehf.
Kauptún 3-7, 210 Gardabaer
Iceland
www.costco.is

Costco France
1 avenue de Bréhat
91140 Villebon-sur-Yvette
France
01 80 45 01 10
www.costco.fr

Costco Wholesale Japan Ltd.
2 Kakuchi, 2 Gaiku, Kaneda-Nishi
361 Urakura, Kisarazu shi
Chiba, 292-0007 Japan
0570-200-800
www.costco.co.jp

Costco Wholesale Korea, Ltd.
40, Iljik-ro
Gwangmyeong-si
Gyeonggi-do, 14347, Korea
1899-9900
www.costco.co.kr

Costco Wholesale New Zealand Limited
2 Gunton Drive
Westgate
Auckland 0814
New Zealand
www.costco.co.nz

Costco (China) Investment Co., Ltd.
Room 01 Mezzanine
No. 5178, Kang Xin Highway
Pudong New District
Shanghai
China 201315
+86-21-6257-7065

MADE IN CHINA